

Control Dump Valves CV10 & CV15 Series

The CV10 and CV15 control valves are compact, cage-guided valves also known as dump valves. They are ideally suited for a wide range of applications such as pressure control, level control and flow control. Typical installations include separators, scrubbers, wellheads and other production equipment.

The CV10 is a close-coupled design, and the CV15 is an open-yoke design.

The hammer union makes maintenance easy by allowing the topworks to be removed without taking the valve out of line. This feature reduces the amount of time needed to inspect and replace the valve trim.

The valves are available in a variety of material options and different trim sizes. A NACE option is also available for sour service.

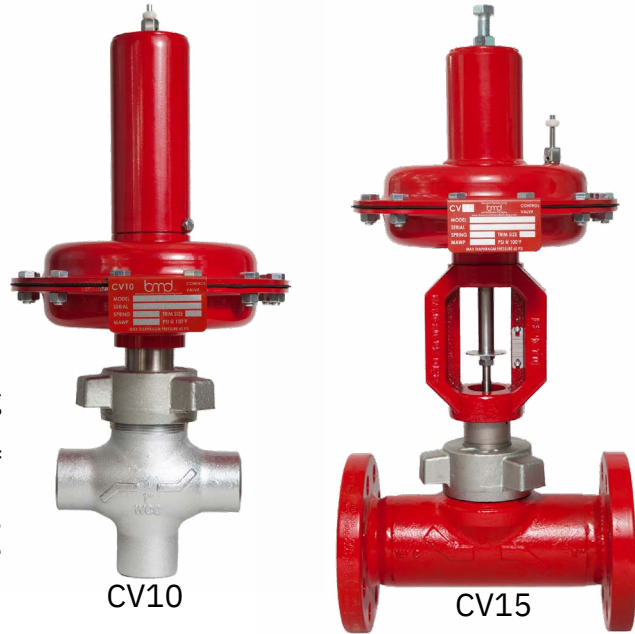

CV10

CV15

All trademarks and service marks used in this document are the property of their respective owners. This Beaumont Manufacturing and Distribution Co. product is exclusively distributed for new equipment packages by FW Murphy in the Natural Gas Compression market.

Specifications

Sizes: 1" and 2"

Connections: Female NPT, flanged, butt weld, socket weld **Body**

Type: Globe, tee (1" only), angle (2" only)

Trim Characteristic: Quick open, modified percent (throttling)

Trim Size: 0.25", 0.375" (3/8"), 0.50", 0.75", 1.00", 1.25", 1.50" requires CV10F/CV15F

Pressure Rating: 4000 psi (-50°F to 200°F), 3755 psi at 400°F

Temperature Range:

CV10 (close-coupled): -50° F to 200° F (-46° C to 93° C)

CV15 (open-yoke): -50° F to 400° F (-46° C to 204° C)

Shutoff: ANSI Class IV

Actuator Sizes: No. 35 (35 in² area), No. 70 (70 in² area)

Input Signal Ranges: 3-15 psi, 6-30 psi

Materials

Body: WCC steel, LCC (low-temp option)

Packing Plug: A105 steel, nickel-plated, A350 LF2 (low-temp option)

Hammer Nut: A105 steel, A350 LF2 (low-temp option)

Trim: 17/4 stainless, carbide (optional)

Actuator Housing: Carbon steel

Yoke: A395 ductile iron

Flow Rates

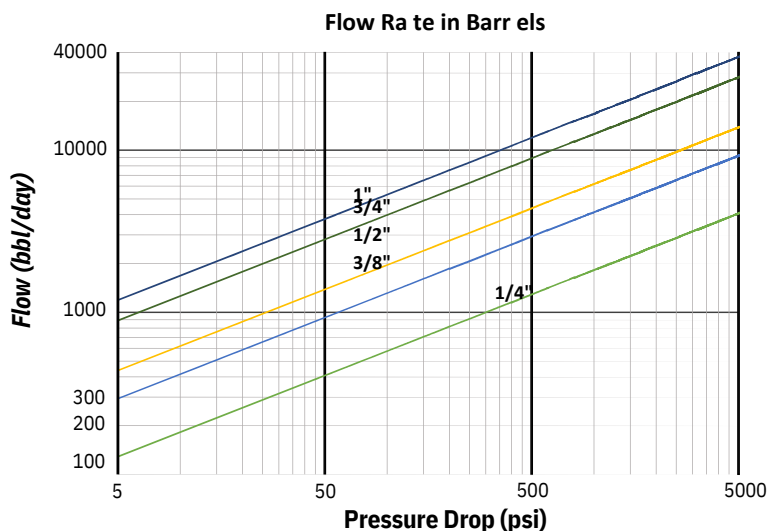

CV10

Cv Values

Body Size	Orifice Size (in.)	Body Style / Valve Opening (% Travel)													
		Modified Percent												Quick Open	
		Globe Body										Angle Body	Globe Body	Angle Body	
		10	20	30	40	50	60	70	80	90	100	100	100	100	
1 Inch	0.25	0.28	0.506	0.657	0.767	0.875	0.989	1.10	1.20	1.32	1.40	1.64	1.68	1.92	
	0.375	4	0.621	0.942	1.28	1.64	2.07	2.51	2.93	3.35	3.70	4.23	3.82	4.34	
	0.50	0.31	1.05	1.59	2.09	2.61	3.14	3.72	4.27	4.96	5.62	6.61	5.70	6.72	
	0.75	1	1.760	2.760	3.82	4.93	6.17	7.49	8.85	10.00	11.00	15.10	11.60	15.20	
	1.00	0.50	2.02	3.44	5.07	6.78	8.42	10.3	12.4	14.3	15.4	20.8	15.5	20.9	
	1.25	2											17.6	21.2	
2 Inch	0.25	0.88	0.506	0.657	0.77	0.88	0.99	1.10	1.20	1.32	1.40	1.66	1.68	1.98	
	0.375	2	0.621	0.942	1.28	1.64	2.07	2.51	2.93	3.35	3.70	4.35	3.82	4.47	
	0.50	1.01	1.170	1.760	2.34	2.95	3.70	4.57	5.50	5.95	6.08	6.90	6.19	7.00	
	0.75		1.81	2.98	4.11	5.74	7.03	8.49	10.1	11.5	12.9	15.2	13.0	15.8	
	1.00	0.28	2.120	3.580	5.43	7.46	9.27	11.40	13.70	15.80	17.10	21.10	18.00	22.00	
	1.25	4											24.0	26.0	
	1.50	0.31											29.0	33.0	

0.59

Shut-Off Pressures

0.88

2

1.08

Maximum Shut-Off Pressures For Reverse-Acting (fail-closed) Actuator

Trim Size (in.)	Flow Direction	Signal to No. 35 Actuator				Signal to No. 70 Actuator			
		3-15 Spring		6-30 Spring		3-15 Spring		6-30 Spring	
		3-15 psig	20 psig	6-30 psig	35 psig	3-15 psig	20 psig	6-30 psig	35 psig
0.25	Up	3800	4000	4000	4000	4000	4000	4000	4000
0.38		2050	3280	3410	4000	3210	4000	4000	4000
0.50		1100	1680	1830	2300	1650	3190	4000	4000
0.75		320	560	690	950	530	940	2020	2800
1.00		110	220	320	490	230	420	960	1460
1.25		70	140	200	310	150	270	610	930
0.25	Down	4000	4000	4000	4000	4000	4000	4000	4000
0.375		4000	4000	4000	4000	4000	4000	4000	4000
0.50		3350	4000	4000	4000	4000	4000	4000	4000
0.75		1580	2300	2530	3270	2080	2800	3780	4000
1.00		770	1100	1240	1680	970	1460	2510	2950
1.25		490	700	790	1080	620	930	1610	1890
1.50		340	490	550	750	430	650	1120	1310

Maximum Shut-Off Pressures For Direct-Acting (fail-open) Actuator

Trim Size (in.)	Flow Direction	Signal to No. 35 Act.1		Signal to No. 70 Act.1		Flow Direction	Signal to No. 35 Act.1		Signal to No. 70 Act.1	
		3-15 Spring	6-30 Spring	3-15 Spring	6-30 Spring		3-15 Spring	6-30 Spring		
Up	0.25	4000	4000	4000	4000	Down	4000	4000	400	400
	0.375	2700	4000	4000	4000		4000	4000	0	0
	0.50	1370	2880	2540	4000		3800	4000	400	400
	0.75	410	1080	730	2020		1750	1940	0	0
	1.00	140	520	230	960		860	940	400	400
	1.25	90	330	150	610		550	600	0	0
1								400	400	

Supply pressure to controller must be at least 5 psi higher

0 0
184 279
0 0
118 179
0 0

Dimensions

End Connection	Body Dimension									
	1" Globe Body			2" Globe Body			1" Tee Body		2" Angle Body	
	A	B	C	A	B	C	C	D	C	D
NPT	6.25	1.56	3.71	7.50	1.69	3.71	3.71	3.13	3.60	3.75
150RFF	7.25	1.56	3.71	10.00	1.69	3.71	3.71	3.63	3.60	5.00
300RFF	7.75	1.56	3.71	10.50	1.69	3.71	3.71	3.88	3.60	5.25
600RFF	8.25	1.56	3.71	11.25	1.69	3.71	3.71	4.13	3.60	5.63
600 RTJ	8.25	1.56	3.71	11.38	1.69	3.71	3.71	4.13	3.60	5.69
900/1500 RFF	9.38	1.56	3.71	12.88	1.69	3.71	3.71	4.69	3.60	6.44
900 /1500 RTJ	9.38	1.56	3.71	13.00	1.69	3.71	3.71	4.69	3.60	6.50

1", 2" Globe Body

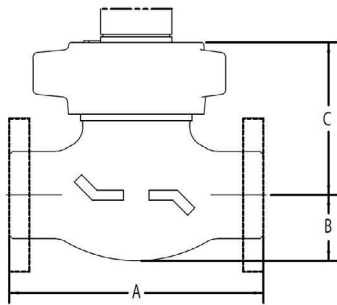

1" Tee Body

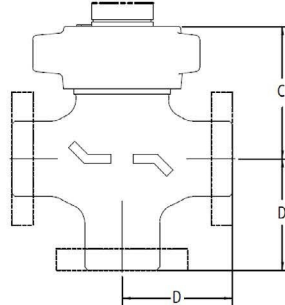

2" Angle Body

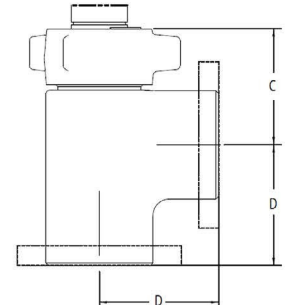

Size	CV10 and CV15 Actuator Dimensions (in.)									
	Direct				Reverse					
	E	F (CV10)	F (CV15)	G	E	F (CV10)	F (CV15)	H (CV10)	H (CV15)	
No. 35, 3-15	9.50	11.51	17.14	5.50	9.50	8.76	14.39	10.91	16.54	
No. 35, 6-30	9.50	13.13	18.76	7.00	9.50	10.63	16.26	11.91	17.54	
No. 70, 3-15	12.5	13.10	18.73	7.00	12.5	10.63	16.26	13.24	18.87	
No. 70, 6-30	0	16.42	22.05	10.00	0	12.38	18.01	15.00	20.63	

12.5
0

CV10

12.5
0

CV15

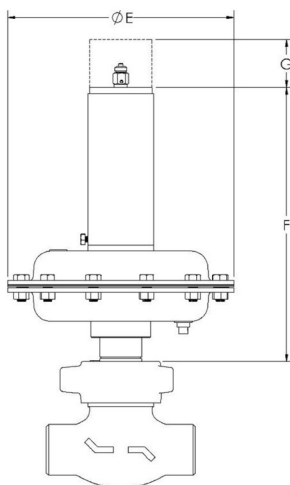

Direct

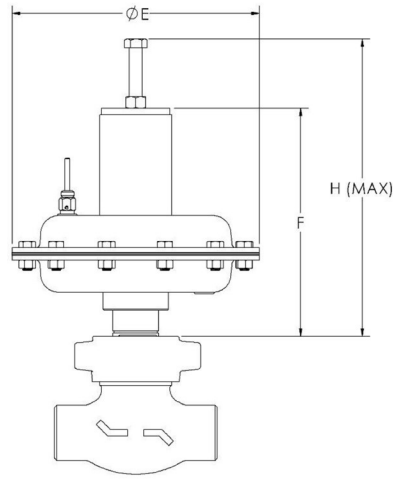

Reverse

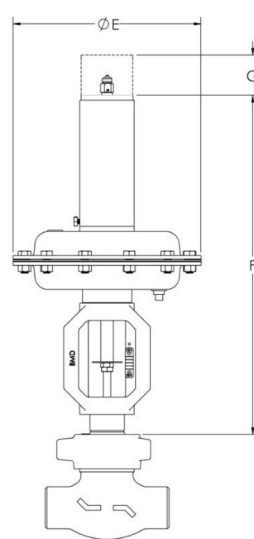

Direct

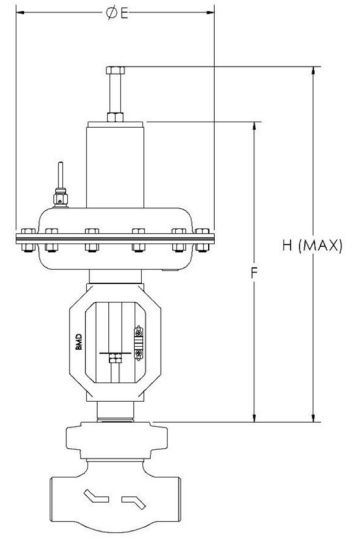

Reverse

Weights

End Connection	Valve Weights with No. 35 Actuator							
	1" Globe		1" Tee		2" Globe		2" Angle	
	lb	kg	lb	kg	lb	kg	lb	kg
NPT	2	11.3	2	12.	32	14.	3	14.5
ANSI 150	5	13.6	8	7	42	5	2	19.1
ANSI 300	3	15.0	3	15.	46	19.	4	20.9
ANSI 600	0	15.9	4	4	48	1	2	21.8
ANSI 900/1500	3	19.1	3	16.	76	20.	4	34.5
	3		7	8		9	6	

End Connection	Valve Weights with No. 70 Actuator							
	5 1" Globe		9 1" Tee		7 2" Globe		8 2" Angle	
	lb	kg	lb	kg	lb	kg	lb	kg
NPT	4	18.1	4	19.6	4	21.3	47	21.3
ANSI 150	0	20.4	3	22.2	7	25.9	57	25.9
ANSI 300	4	21.8	4	23.6	5	27.7	61	27.7
ANSI 600	5	22.7	9	24.5	7	28.6	63	28.6
ANSI 900/1500	4	25.9	5	28.1	6	41.3	91	41.3
	8		2		1			

How to Order

Options are listed below. All configurations may not be available. Call your sales representative or FW Murphy for more information. Repair kits are available.

Example Model No. **CV10-1N50R33-3-CB-2Q-T**

CV10 Series Dump Valve, 1" Globe Body, Threaded Ends, No. 35 Reverse Act, 3-15 Spring, Carbon Steel with Buna Seals, 0.25" Quick Open SST Trim, 1/4" Tapped Body

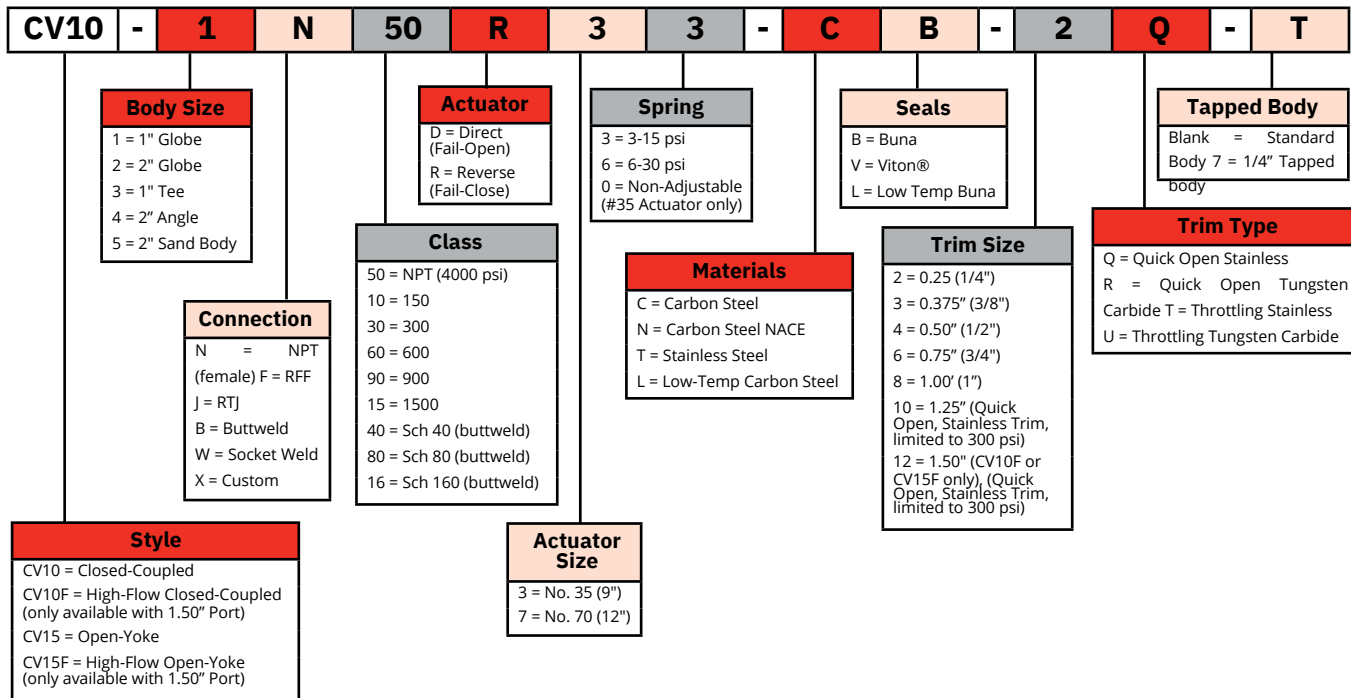

FW Murphy is the exclusive BMD distributor for new equipment packages.